

MOTOR KIT FOR INTEGRATED ROLLER SHUTTER - Ø 40mm tube

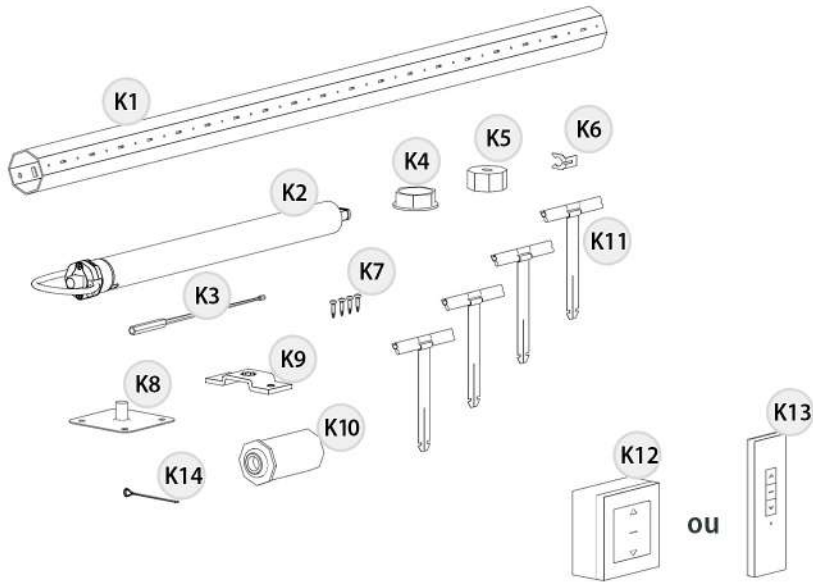

REMOVAL OF OLD MECHANISM

It is possible that the tube to be replaced contains a loaded spring. To remove the tube, it will be necessary to relax the spring to avoid any damage or injury.

For step **2**, follow the steps according to your installation:

- Type 1 = my tube has a spring.
- Type 2 = my tube has no spring.

1 Remove the access hatch (type 1 and type 2).

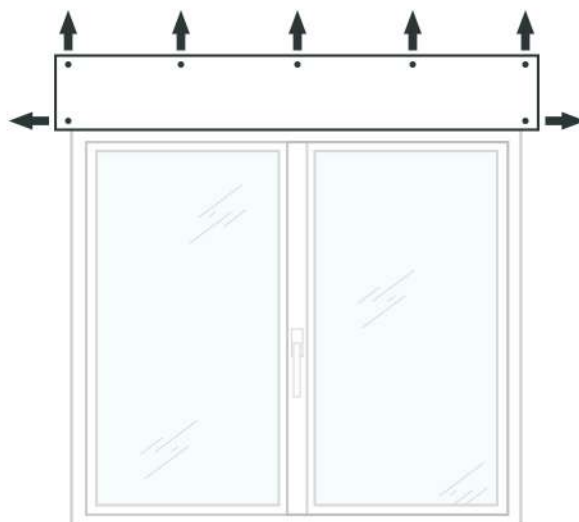

Inside view

2 Type 1:

- A** Mark the position of the tube relative to its support on each side of the tube.

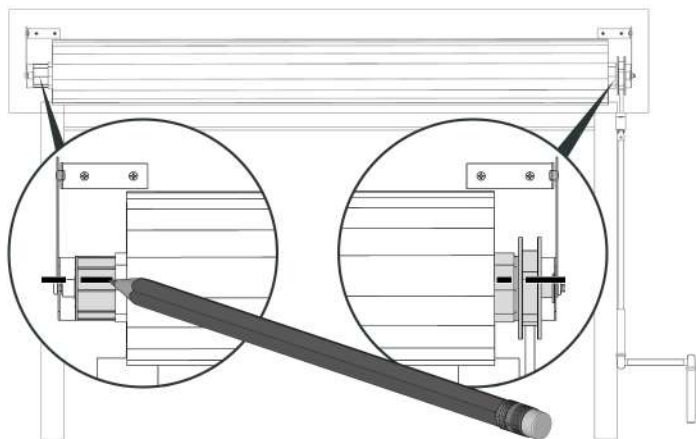

- B** Lower the shutter, counting the number of rotations (using the marks made in the previous step).

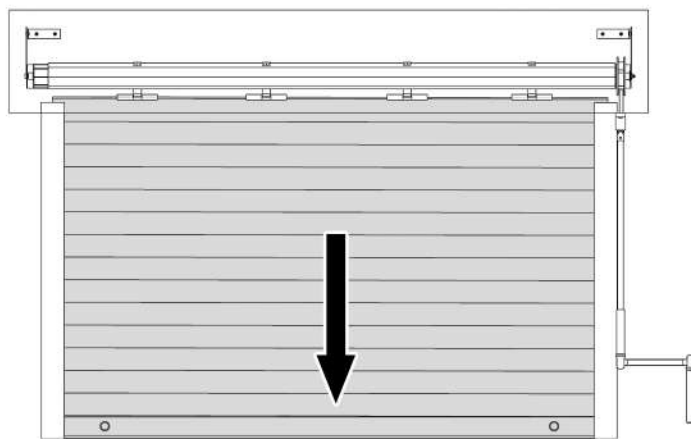

- C** Detach the roller shutter from its tube, taking care to identify the rolling direction of the curtain.

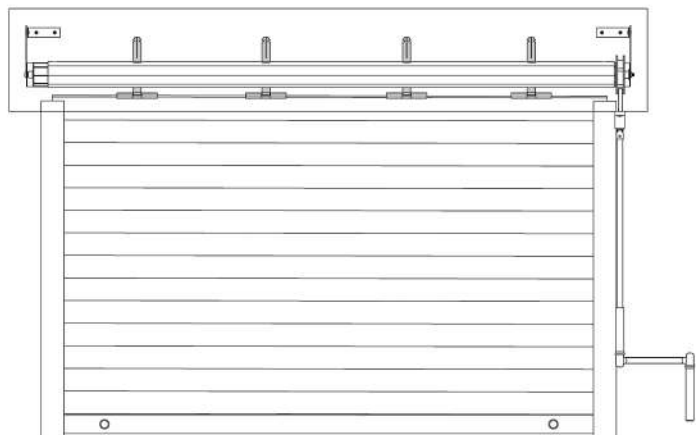

- D** Loosen the spring with the crank: turn the tube the number of rotations marked in step B in the opposite direction (up). Disassemble and remove the crank mechanism.

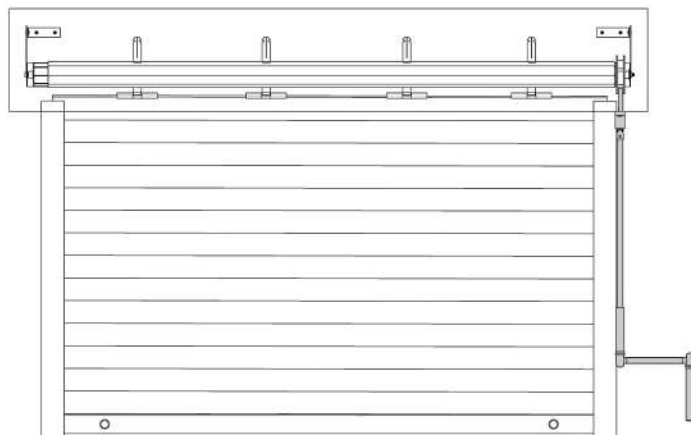

2 Type 2:

- A** Lower the roller shutter.



- B** Detach the roller shutter from its tube, taking care to identify the rolling direction of the curtain.

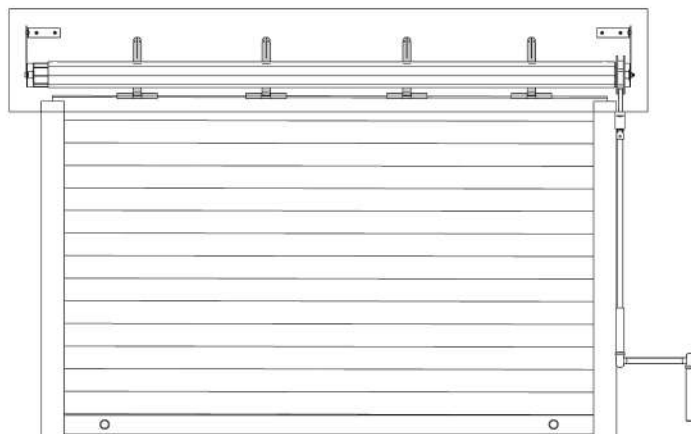

3 Mark the exact location of the tube on the 2 support brackets.

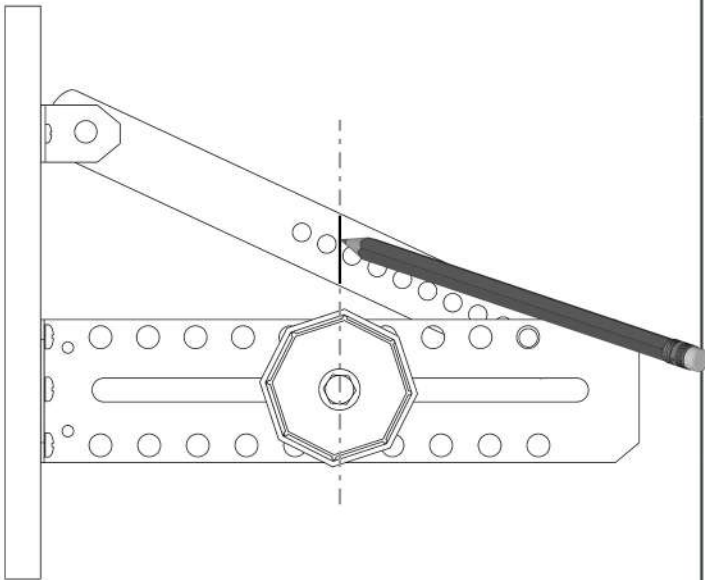

4 On the opposite side of the control, separate the tube end from the tube (screwed / rified depending on manufacturer).

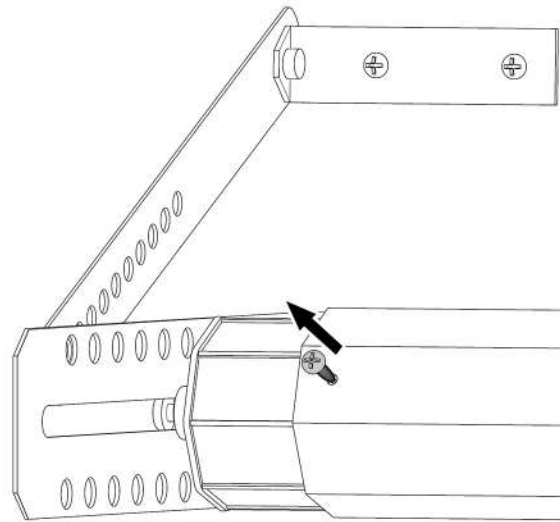

5 If strap coiler, remove the coiler box from the wall and remove the strap from the strap guide (turn the tube in on itself to reach the fixing point).

Fit the tube fully onto the tube end, and remove.

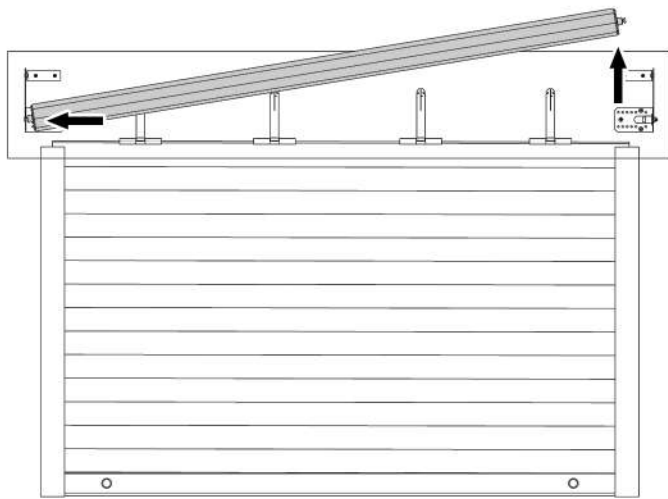

6 Remove the supports on each side.
Do not dismantle the existing brackets.

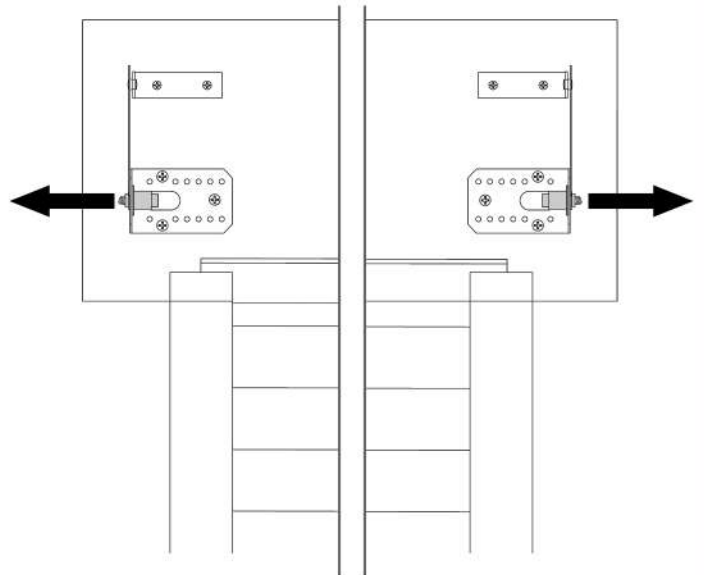

TUBE DIMENSIONS

7

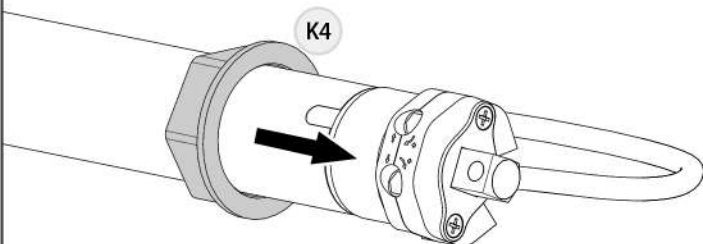

8

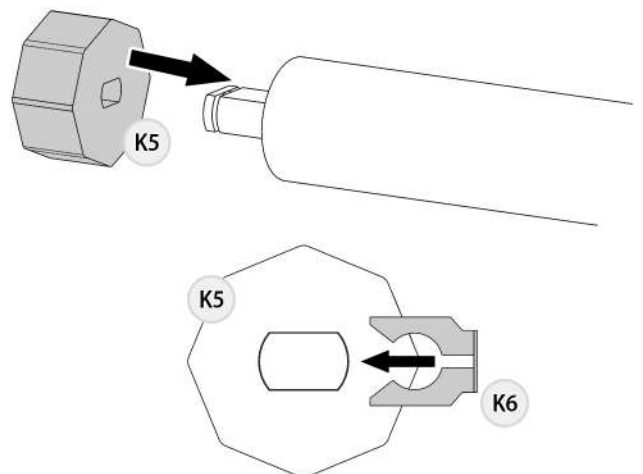

9 **A** Measure: motorhead + crown adapter.

$M = \text{Cm}$

B Measure the protruding part of the tube end.

$E = \text{Cm}$

$T = M + E + 3 \text{ Cm} = \text{Cm}$

10 Measure the width between brackets.

$L = \text{Cm}$

11 Dimension of the tube alone (A).

$A = L - T = \text{Cm}$

ASSEMBLY OF THE NEW MOTORISED TUBE

12 On the brackets left in place, marked in step 3:

- Attach the motor support (K9) on the control side. The gaps allowing you to make motor adjustments must be in front of you
- Fix the pivot plate with stud (K8) opposite to the control side.

Match the positioning of the tube marked in step 3.

13 Measure distance P, to secure the motor without damaging it.

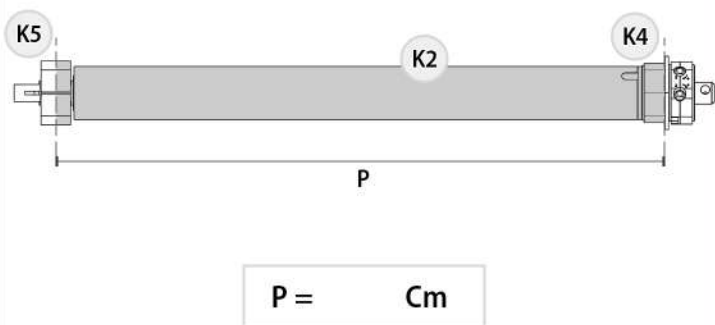

14 Insert the motor into the tube.
Mark measurement P on the tube, then screw the tube to the motor wheel (K5) with one of the supplied screws (K7).

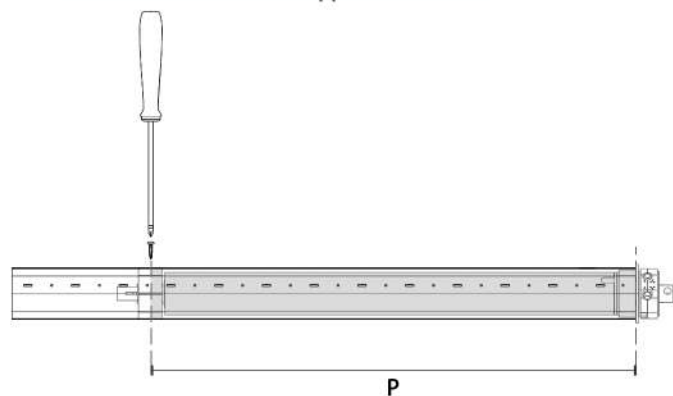

15 Fit the tube end (K10) on the tube.

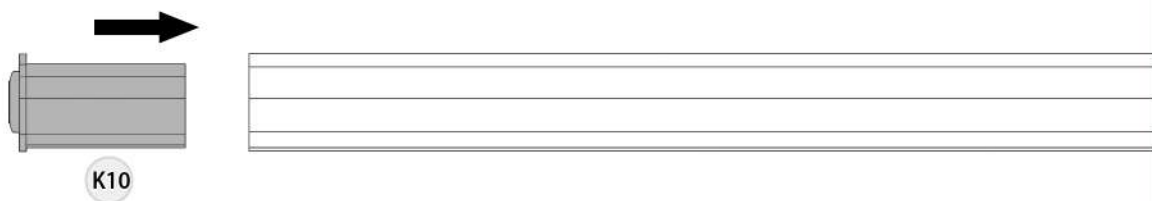

16 Raise the first slat and attachment clips, then position the tube on its supports.

Attention : the motor stop limit adjustment screws must face you.

- Fit the motor head on to the motor support (K9), insert the pin (k14) through the 10mm square. Cross the pin ends to secure it.
- Position the other end of the tube facing the stud plate (K8). Pull the end of the tube to make it lodge onto the stud.

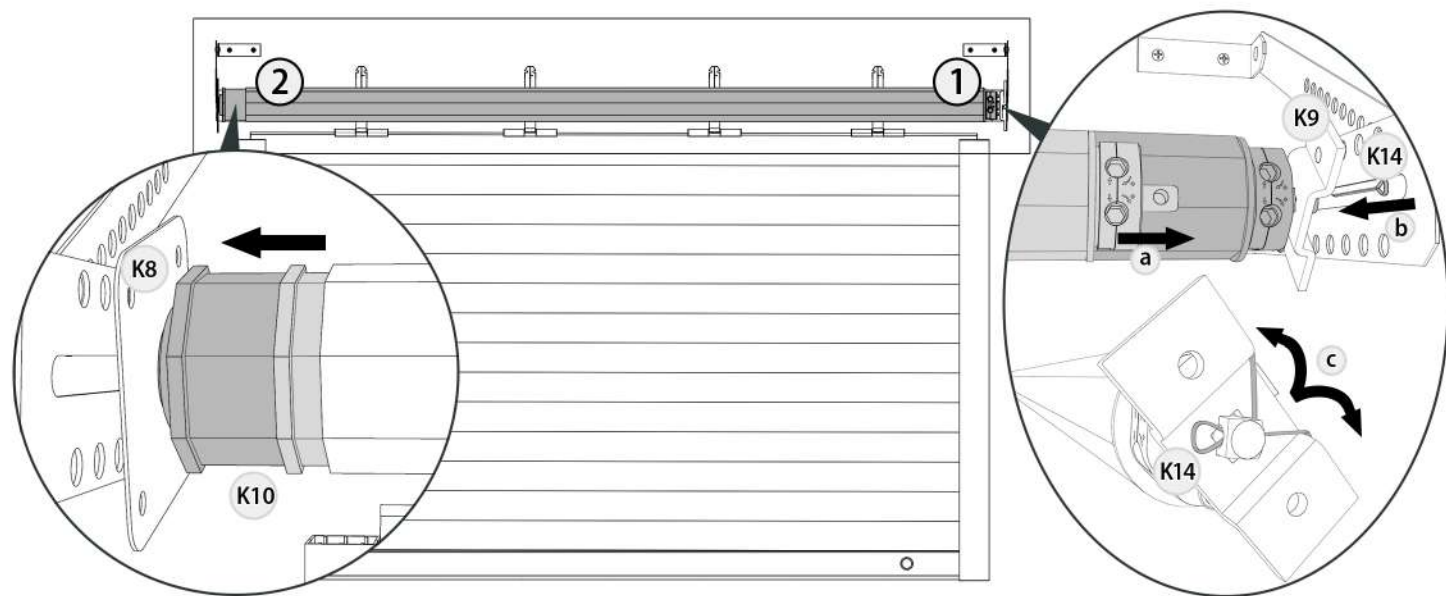

17 Secure the tube (opposite side to the motor) onto the tube end (K10) with one of the screws provided.

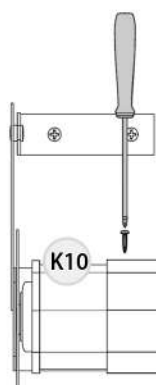

- 20 Reattach the shutter curtain to the tube, paying attention to the rolling direction of the deck (noted in step 2).

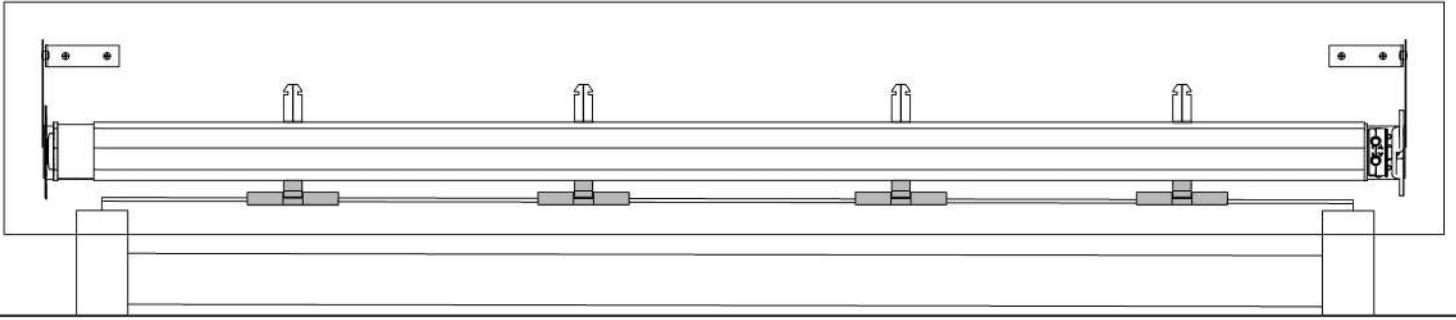

- 21 Make the connections according to the diagram corresponding to your motor. Adjust the upper and lower stops, referring to the instructions for your motor. Then close the access box.



Wired switch motor:

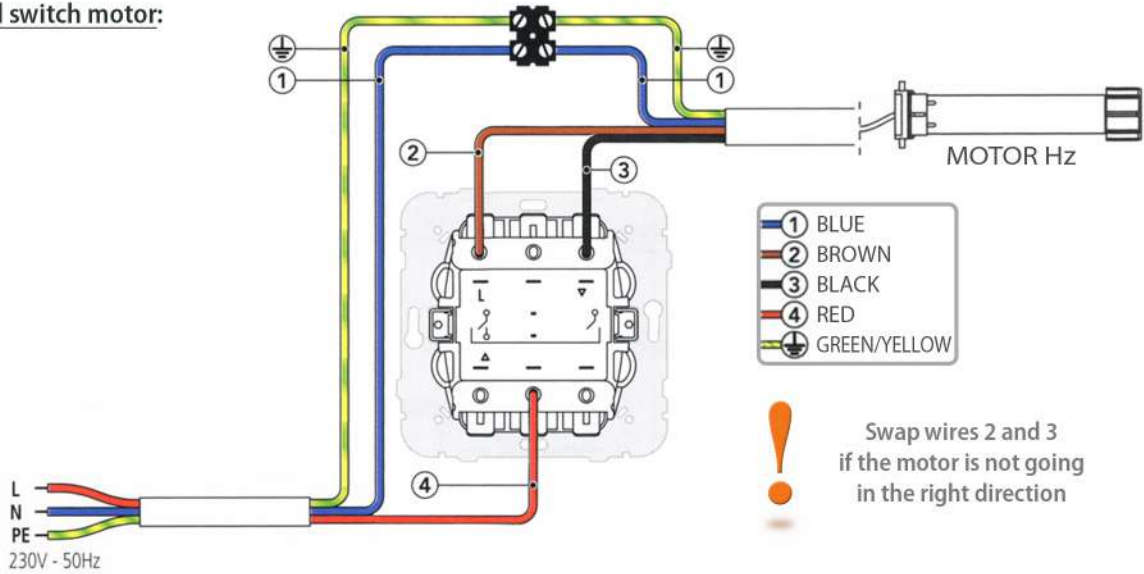

Wiring 4 wire motors

Multiple motors on 1 switch: Do not wire more than 2 or more motors in on the same unipolar switch.

Remote control motor:

